

EN1941XS One-Way Serial RF Module Installation and Operation Manual

1 Overview

The Inovonics EN1941XS one-way serial data RF module provides reliable low-cost, low-power serial wireless communication for integrators. The EN1941XS is a universal one way RF module that allows for the transmission of up to 50 bytes of user defined serial data. This module connects to a serial interface to transmit variable data such as temperature, humidity, pressure, or liquid levels to a head end application controller.

The EN1941XS, equipped with the UART logic-level serial connection, is primarily intended for use as a daughter board, interfacing directly with your RAC.



Figure 1 One-way system components

The one-way serial RF module is available in North America, Australia and New Zealand; the radio frequency band has been configured for the appropriate geographic area at the factory.

1.1 Maximum Number of Repeaters for a UL 2560 Installation

To achieve the 99.99% alarm message reliability required for UL 2560 compliance, system installations must operate within the following limits for end device and repeater counts.

End Devices	Maximum Repeaters
150	397
250	386
350	375
500	360
1000	313
2000	238
3000	184

1.2 Inovonics Wireless Contact Information

▶ For product and installation videos visit us at www.inovonics.com/videos or use the QR code below.



If you have any problems with this procedure, contact Inovonics Wireless technical services:

- E-mail: support@inovonics.com
- Phone: (800) 782-2709; (303) 939-9336

2 One-Way Serial RF Module Components

The EN1941XS one-way serial RF module is designed to physically interface with your product. Serial data sent to the EN1941XS from your

remote application controller is formatted by the EN1941XS, and the data is then transmitted as an RF message to the network coordinator.

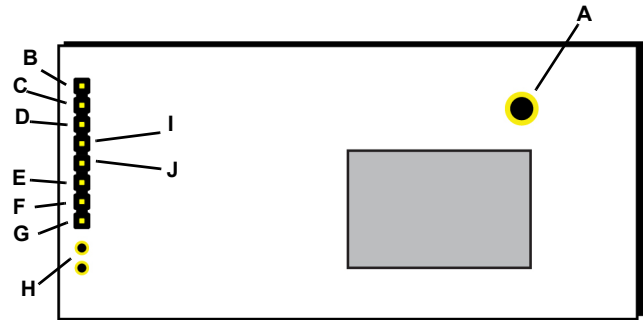

Figure 2 One-way serial RF module components

- | | | |
|--------------------------|-----------------------|-----------------------|
| A Mounting hole | B Data output | C Data input |
| D Secondary alarm | E Power | F Ground |
| G Primary alarm | H LED contacts | I Tamper input |
| J Reset input | | |

Secondary alarm Driving pin high triggers a secondary serial alarm status message.

Primary alarm Driving pin high triggers a primary serial alarm status message.

Tamper input Driving pin high triggers a serial tamper status message from the RF module to the RAC. Does not trigger an RF tamper message.

Reset input Connects a reset input, to reset the one-way serial data RF module.

Power Connect power cabling to an external power supply of 2.6 to 5.5 volts.

Ground Connects to ground.

Mounting hole Used to mount the one-way serial data RF module to the user-specific product. The mounting hole should only be used with a nylon standoff, never metal.

Data output Outputs messages to the RAC.

Data input Receives messages from the RAC.

3 One-Way Serial RF Module Dimensions

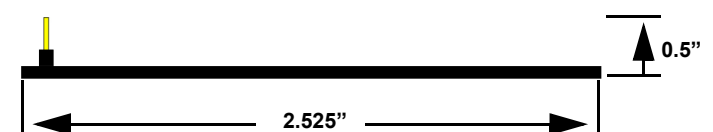
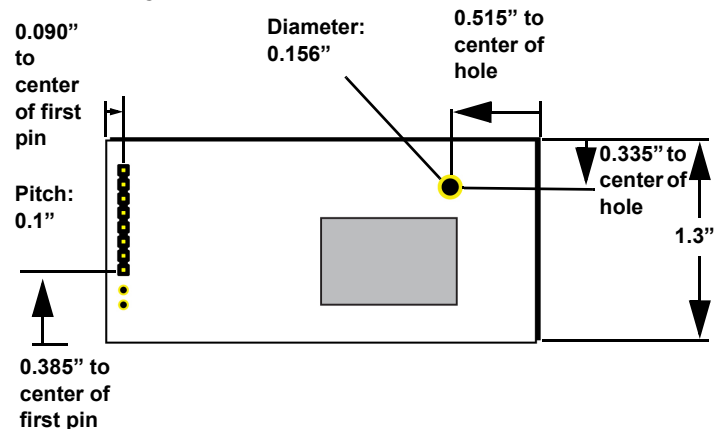

Figure 3 One-way serial RF module dimensions



4 One-Way Serial RF Module Connections and Output Jumpers

	Connection	Output Jumper N/C
Primary Alarm	Open	Alarm
	Ground	Alarm Clear
Secondary Alarm	Open	Alarm
	Ground	Alarm Clear
Tamper	Open	Tamper
	Ground	Tamper Clear
Reset	Open for normal operation; connect to the ground and release for a board reset.	

5 Installation Notes

- The RF module must only be connected at the eight pin header or eight pin plated thru-holes.
- All cables and wires must be routed away from the component side of the RF module.
- The integrated antenna must not be tampered with; no connection to an alternate antenna is provided.
- The application module must not include an integrated secondary colocated radio module.
- The one-way serial data RF module antenna should be placed so that it is facing away, or otherwise isolated from, your device's ground plane.
- Components that are sensitive to RF transmission, such as high gain circuits, should be isolated from the antenna to prevent interference.
- One-way serial RF modules should not be mounted on metal surfaces or inside metal enclosures. They should also not be mounted where sheet metal ductwork, wire mesh screens, etc. might block transmissions.

6 One-Way Serial RF Module Requirements

6.1 Timing Requirements

All data is sent at a default rate of 9600 baud, no parity, 8 data bits and one stop bit. The data is transmitted least significant bit first.

6.2 Power Requirements

The EN1941XS has an on-board voltage regulator. Connect power cabling to an external power supply (Vcc) of 2.6 to 5.5 volts. Voltage must be sustained at 2.6 volts or above and supply 100 milliamps during the transmit cycle.

Assuming check-in messages every 3 minutes and infrequent alarm messages (one per day, on average), the average current draw is 32 μ A. Peak current draw while transmitting is less than 100 mA. One alarm/restore cycle with the maximum payload size results in approximately a 23mA increase in the average current.

6.3 Low Battery Condition

The EN1941XS measures power supply voltage every three and a half hours, and, when the voltage measures 2.6 volts, a serial message is sent indicating a low battery condition.

6.4 Temperature Range

-20°C to +60°C, non-condensing.

6.5 RF Network Compatibility

EchoStream Commercial Mesh Network.

6.6 Payload size

50 bytes maximum.

6.7 Input Requirements

Caution: Input levels must not exceed 3.3 V.

Open When an active source (open collector or dry contact) is used to drive the alarm or tamper input, the voltage should be between $0.75 \times V_{cc}$ and V_{cc} . A passive input should have an impedance of greater than 5.1k ohm between the input and ground.

Closed When an active source is used, the voltage should be less than $0.25 \times V_{cc}$. A passive input should have an impedance of less than 240 ohm.

6.8 Serial I/O - UART logic-levels

Input levels must not exceed 3.3 V. Output levels are limited to 3.3 V, maximum.

Data in pins V_{ih} (minimum high level input voltage): $0.75 \times V_{cc}$.

Data in pins V_{il} (maximum low level input voltage): $0.25 \times V_{cc}$.

Data out pins V_{oh} (minimum high level output voltage): $V_{cc} - 0.25$ at Ioh: -1.5mA.

Data out pins V_{oh} (minimum high level output voltage): $V_{cc} - 0.6$ V at Ioh: -6mA.

Data out pins V_{ol} (maximum low level output voltage): 0.25 V at Iol: 1.5 mA.

Data out pins V_{ol} (maximum low level output voltage): 0.6 V at Iol: 6 mA.

6.9 UL2560 Requirements

- The EN1941XS one-way serial RF module is a UL2560 unlisted component.
- The compatible receiver for UL 2560 installations is the EN6040-T network coordinator. Refer to the *EN6040-T Network Coordinator Installation Instructions*.
- For UL 2560 installations, the RF module must have a minimum check-in time of 60 minutes.
- The compatible repeater for UL 2560 installations is the EN5040-20T.
- In a UL 2560 installation, the EN1941XS one-way serial RF module may be used with completed emergency call systems for assisted living and independent living facilities.
- For UL 2560 certified system installations, the following Inovonics EchoStream devices are approved for installation within maximum system configuration limits defined in section 1.1 of this document:
 - EN6040-T network coordinator.
 - EN5040-20T high power repeater.
 - End devices (transmitters) with a minimum 60-minute check-in interval, as follows:
 - Fundamental devices which are subject to UL2560 certification (pendant transmitters and OEM products using the Inovonics RF module).
 - Supplemental devices which are not subject to UL2560 system certification but which may be used within a UL2560 certified system (e.g. universal transmitters and activity sensors).
- Users that have achieved certification and will install UL 2560 certified systems are responsible for labeling all fundamental devices with the UL 2560 system certification mark.

7 Compliance Requirements

7.1 FCC Requirements for the EN1941XS

The EN1941XS one-way serial data RF module has received a Modular Grant to FCC/IC regulations. The integrator is responsible to test the final installation to verify compliance to FCC/IC regulation for unintentional emissions.

The integrator is responsible for properly labeling the product containing the one-way serial data RF module. Labels must be placed on the outside of the product, and must include a statement indicating that the product contains the module, along with the FCC and IC number.

Example:

Contains FCC ID: HCQTBA

Contains IC: 2309A-TBA

8 Television and Radio Interference

This equipment has been tested and found to comply with the limits for a Class B digital device, pursuant to Part 15 of the FCC Rules. These limits are designed to provide reasonable protection against harmful interference in a residential installation. This equipment generates, uses and can radiate radio frequency energy and, if not installed and used in accordance with the instructions, may cause harmful interference to radio communications. However, there is no guarantee that interference will not occur in a particular installation. If this equipment does cause harmful interference to radio or television reception, which can be determined by turning the equipment off and on, the user is encouraged to try to correct the interference by one or more of the following measures:

- Reorient or relocate the receiving antenna.
- Increase the separation between the equipment and receiver.
- Connect the equipment into an outlet on a circuit different from that to which the receiver is connected.
- Consult the dealer or an experienced radio/TV technician for help.

9 FCC Part 15 and Innovation, Science and Economic Development Canada (ISED) Compliance

This device complies with part 15 of the FCC Rules, and ISED license-exempt RSS standard(s). Operation is subject to the following two conditions: (1) this device may not cause interference, and (2) this device must accept any interference that may cause undesired operation of the device.

Le présent appareil est conforme aux CNR Innovation, Sciences et Développement économique Canada applicables aux appareils radio exempts de licence. L'exploitation est autorisée aux deux conditions suivantes: (1) l'appareil ne doit pas produire de brouillage, et (2) l'utilisateur de l'appareil doit accepter tout brouillage radioélectrique subi, même si le brouillage est susceptible d'en compromettre le fonctionnement.

10 Radiation Exposure Limits

10.1 FCC

This equipment complies with FCC radiation exposure limits set forth for an uncontrolled environment. In order to avoid the possibility of exceeding the FCC radio frequency exposure limits, human proximity to the antenna shall not be less than 20 cm during normal operation and must not be co-located or operating in conjunction with any other antenna or transmitter.

10.2 ISED

This equipment complies with ISED RSS-102 radiation exposure limits set forth for an uncontrolled environment. This transmitter must be installed to provide a separation distance of at least 20 cm from all persons and must not be co-located or operating in conjunction with any other antenna or transmitter.

Cet équipement est conforme avec ISED RSS-102 des limites d'exposition aux rayonnements définies pour un environnement non contrôlé. Cet émetteur doit être installé à au moins 20 cm de toute personne et ne doit pas être colocalisé ou fonctionner en association avec une autre antenne ou émetteur.

Note: Specifications and data are subject to change without notice.

Note: Inovonics supports recycling and reuse whenever possible. Please recycle these parts using a certified electronics recycler.
