



EN1212 Family Dual Input Universal Installation Instructions

1 Overview

The dual input universal is designed to be used with any standard contact or sensor. Inovonics multi-function add-on receivers will support both inputs as separate devices. The dual input universal is available in North America, Australia and New Zealand; the radio frequency band has been configured for the appropriate geographic area at the factory. The dual input universal is available in the following configurations:

Part #	Check-In
EN1212	3 minutes
EN1212-60	60 minutes

Note: The dual input universal requires use of a serial receiver or network coordinator, as well as an application designed to support advanced functionality.

Note: For UL 2560 installations, refer to the *EN6080 Area Control Gateway Installation Instructions*.

1.1 Maximum Number of Repeaters for a UL 2560 Installation

To achieve the 99.99% alarm message reliability required for UL2560 compliance, system installations must operate within the following limits for end device and repeater counts.

End Devices	Maximum Repeaters
150	397
250	386
350	375
500	360
1000	313
2000	238
3000	184

1.2 Inovonics Contact Information



If you have any problems with this procedure, contact Inovonics Wireless technical services:

- E-mail: support@inovonics.com.
- Phone: (800) 782-2709.

1.3 Dual Input Universal Internal Components

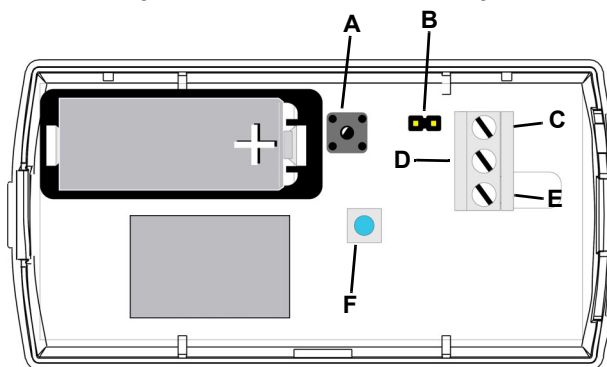

Figure 1 Dual input universal components

- A** Housing tamper button
- B** NO/NC selection pins
- C** Input one terminal
- D** Ground terminal
- E** Input two terminal
- F** Reset button

1.4 What's In The Carton

- Three wall mount screws.
- Three wall mount anchors.
- Two selection jumpers.
- One 3.0V lithium battery.

2 Installation and Startup

2.1 Installation Notes

- These products are designed to be installed and maintained by professional security technicians.
- Products are intended for indoor use.
- Manually test all products weekly.

2.2 Install/Replace the Battery

1. Pry the top lip of the mounting bracket up, and lift the bracket off of the transmitter.
2. Use your thumb to depress the housing release tab on the bottom of the transmitter; separate the housing.
3. Install the battery.
4. Press the reset button to initialize the transmitter.

2.3 Connect Input Wiring

The transmitter has a three-terminal contact block that can connect inputs from one or two external contact loops. The middle terminal is a ground, which is shared by both contact loops. Input one can be configured for either a normally open or a normally closed contact loop using the NO/NC selection pins; input two is always normally closed.

1. Connect wiring for the inputs you will be using.
2. If you are not using input two, connect wiring between the input terminal and the ground terminal to set it for normally closed.

2.4 Select Input Type

The N/O-N/C selection pins allow the choice of a normally open or normally closed state for the contact circuit wired to the input one terminal. The terminal is shipped set for normally closed, with no selection jumper on the N/O selections pins.

1. Place a selection jumper on the selection pins to select normally open; remove the selection jumper from the selection pins to select normally closed.
2. Press the reset button to complete configuration.

2.5 Register the Dual Input Universal

Transmitters must be registered with the system in order to be monitored and supervised. When supervised, the transmitter will send a check-in message to the receiver. EN1212 transmitters send a check-in message every three minutes; EN1212-60 transmitters send a check-in message every 60 minutes. Each transmitter has a unique factory-programmed identification number.

Note: For UL 2560 installations, transmitters must have a minimum check-in time of 60 minutes.

Refer to the receiver installation instructions for details about registering a transmitter.

1. When prompted by the receiver to reset transmitter, press the reset button.
2. Replace the cover.

Caution: The dual input universal should be tested after registration to ensure operation. To test the transmitter, activate each of the conditions and ensure an appropriate response.

2.6 Mount the Transmitter

1. Mount the bracket on the wall with the screws provided.

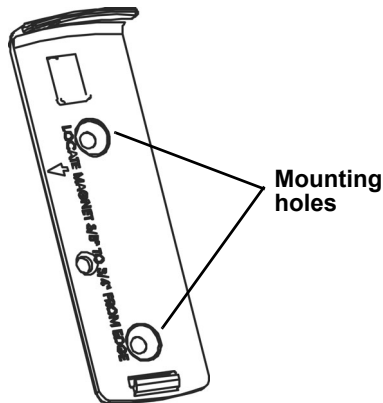

Figure 2 Mount the bracket

2. Clip the transmitter onto the bracket. Hook the bottom catch first, then press the top into place.
3. As desired, use the third mounting screw to secure the housing through the screw hole located beneath the battery.

Note: Accessing this screw on an active transmitter requires opening the housing and removing the battery, causing a tamper condition.

4. Replace the housing cover.

3 Specifications

External contacts: NO or NC.

Distance, external contact to transmitter: 10 feet (3 meters) maximum.

Typical battery life: 3-5 years.

Battery type (BAT604): Panasonic CR123A or equivalent.

Operating environment: -4° to 140°F (-20° to 60°C), noncondensing.

Compatible receiver for UL 2560 installations with the EN1212-60: EN6080.

Compatible repeater for UL 2560 installations with the EN1212-60: EN5040-20.

Note: Inovonics supports recycling and reuse whenever possible. Please recycle these parts using a certified electronics recycler.

Note: The EN1212-60 is a supplemental device that can be installed in a UL 2560 certified system.

Note: Specifications and data are subject to change without notice.

4 Television and Radio Interference

This equipment has been tested and found to comply with the limits for a Class B digital device, pursuant to Part 15 of the FCC Rules. These limits are designed to provide reasonable protection against harmful interference in a residential installation. This equipment generates, uses and can radiate radio frequency energy and, if not installed and used in accordance with the instructions, may cause harmful interference to radio communications. However, there is no guarantee that interference will not occur in a particular installation. If this equipment does cause harmful interference to radio or television reception, which can be determined by turning the equipment off and on, the user is encouraged to try to correct the interference by one or more of the following measures:

- Reorient or relocate the receiving antenna.
- Increase the separation between the equipment and receiver.
- Connect the equipment into an outlet on a circuit different from that to which the receiver is connected.
- Consult the dealer or an experienced radio/TV technician for help.

5 FCC Part 15 and Innovation, Science and Economic Development Canada (ISED) Compliance

This device complies with part 15 of the FCC Rules, and ISED license-exempt RSS standard(s). Operation is subject to the following two conditions: (1) this device may not cause interference, and (2) this device must accept any interference that may cause undesired operation of the device.

Le présent appareil est conforme aux CNR Innovation, Sciences et Développement économique Canada applicables aux appareils radio exempts de licence. L'exploitation est autorisée aux deux conditions suivantes: (1) l'appareil ne doit pas produire de brouillage, et (2) l'utilisateur de l'appareil doit accepter tout brouillage radioélectrique subi, même si le brouillage est susceptible d'en compromettre le fonctionnement.

6 Radiation Exposure Limits

6.1 FCC

This equipment complies with FCC radiation exposure limits set forth for an uncontrolled environment. In order to avoid the possibility of exceeding the FCC radio frequency exposure limits, human proximity to the antenna shall not be less than 20 cm during normal operation and must not be co-located or operating in conjunction with any other antenna or transmitter.

6.2 ISED

This equipment complies with ISED RSS-102 radiation exposure limits set forth for an uncontrolled environment. This transmitter must be installed to provide a separation distance of at least 20 cm from all persons and must not be co-located or operating in conjunction with any other antenna or transmitter. Cet équipement est conforme avec ISED RSS-102 des limites d'exposition aux rayonnements définies pour un environnement non contrôlé. Cet émetteur doit être installé à au moins 20 cm de toute personne et ne doit pas être colocalisé ou fonctionner en association avec une autre antenne ou émetteur.