



EN1241-60 EchoStream® Activity Sensor Installation Instructions

1 Overview

The EN1241-60 activity sensor is designed specifically for residential and senior living environments where a notification of a daily activity is necessary. The EN1241-60 leverages the latest motion detector technology, including white light and pet immunity, to ensure performance accuracy. Selectable fixed sleep intervals of two, four, or six hours are used to minimize wireless traffic in large installations, while confirming daily resident activity. Check-in messages are sent every 60 minutes to provide effective notification of recent resident activity even when the device is in the fixed sleep cycle.

Note: For UL 2560 installations, refer to the *EN6080 Area Control Gateway Installation Instructions*.

Caution: The EN1241-60 needs one minute for stabilization after power up. During the stabilization period, the LED will blink twice per second, and the EN1241-60 will not be operational.

Caution: Prior to operation, the EN1241-60 must be acclimated to the temperature of the install environment for a period of 60 minutes.

Caution: The EN1241-60 activity sensor is not designed for use as a security system motion detector.

1.1 Maximum Number of Repeaters for a UL 2560 Installation

To achieve the 99.99% alarm message reliability required for UL 2560 compliance, system installations must operate within the following limits for end device and repeater counts.

End Devices	Maximum Repeaters
150	397
250	386
350	375
500	360
1000	313
2000	238
3000	184

1.2 Inovonics Wireless Contact Information

If you have any problems with this procedure, contact Inovonics Wireless technical services:

- E-mail: support@inovonics.com.
- Phone: (800) 782-2709; (303) 939-9336.

1.3 EN1241-60 Internal Components

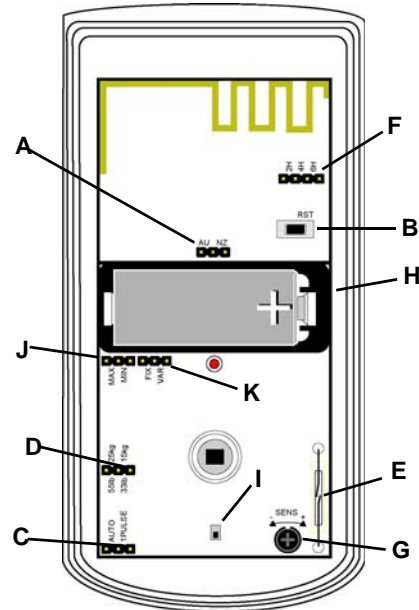

Figure 1 EN1241-60 components

- A Frequency band selection pins
- B Reset button
- C Pulse count selection pins
- D Pet immunity selection pins
- E Test mode reed switch
- F Sleep duration selection pins
- G Sensitivity adjustment dial
- H Battery
- I Case tamper switch
- J Sleep duration selection pins
- K Sleep time selection pins

1.4 What's In The Carton

- Three wall mount screws.
- Three wall mount anchors.
- One selection jumper.
- One 3.0V lithium battery.

2 Installation and Startup

2.1 Installation Notes

- These products are designed to be installed and maintained by professional security technicians.
- Products are intended for indoor use.
- Manually test all products weekly.

2.2 Install/Replace Battery

To install the battery:

1. Release the housing screw and gently raise the cover.

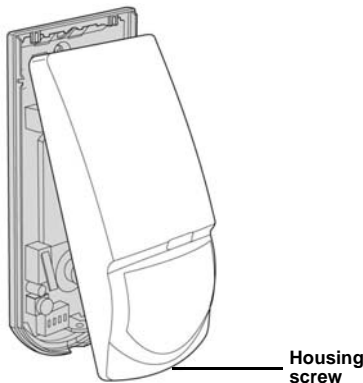

Figure 2 Open the cover

2. Install the battery in the holder.
3. Press the reset button to initialize the transmitter.

Note: You must press the reset button each time the battery is changed.

2.3 Select the Frequency Band

EchoStream products are able to use a range of radio frequencies, and must be configured for your geographic area. This product ships with a default frequency range of 902-928 MHz for use in North America. If you are using the product in North America, skip to section 2.4, "Select Automatic/Pulse Count"; if you are using the product in Australia or New Zealand, you will need to configure the transmitter.

4. Place a selection jumper on the appropriate frequency band selection pins.
 - Place the jumper on the right two pins, marked NZ, to set the frequency range to 921-928 MHz for New Zealand.
 - Place the jumper on the left two pins, marked AU, to set the frequency range to 915-928 MHz for Australia.
5. Press the reset button to complete configuration.

Caution: When pressing the reset button, make sure you don't also touch the frequency band selection pins. Touching the frequency band selection pins while pressing the reset button can inadvertently set the EN1241-60 to the wrong frequency band.

2.4 Select Automatic/Pulse Count

The pulse count jumper setting provides control for normal or difficult operating environments. Automatic pulse count is recommended for reliable operation in environments subject to temperature fluctuations that may cause false alarms. The single pulse count mode is more sensitive to minor temperature variations, and should be used in sites where variant heat sources will not cause false alarms.

6. Place a selection jumper on the appropriate pulse count selection pins.
 - Place the jumper on the left two pins, marked AUTO, to select automatic pulse count.
 - Place the jumper on the right two pins, marked 1 PULSE, to select single pulse count.

2.5 Select Fixed/Variable Sleep Time

The EN1241-60 activity sensor is shipped from the factory set for a fixed sleep time. The fixed/variable sleep time setting should not be changed without specific instruction from Inovonics technical services.

2.6 Select Sleep Duration

The EN1241-60 activity sensor is shipped from the factory set for a minimum sleep duration. The sleep duration setting should not be changed without specific instruction from Inovonics technical services.

2.7 Select Fixed Sleep Time

Alarm and Check-In Messages

The EN1241-60 sends two types of message: alarm and check-in. Alarm messages are sent when the EN1241-60 first detects motion. Immediately upon sending an alarm message, the EN1241-60 enters the selected sleep cycle, during which no more alarm messages are sent. Check-in messages are sent by the EN1241-60 every 60 minutes, even during the sleep cycle, to ensure the EN1241-60 is still functional. Check-in messages also include the alarm status as part of the check-in information.

Using Sleep Cycles

Typically, activity monitoring in senior living environments is performed using a daily time window to confirm resident activity. The EN1241-60 sleep interval can be set to two, four, or six hours. If you require multiple alarms during your daily time window you should select a sleep time shorter than your daily time window.

Setting Sleep Cycle Duration

To set sleep cycle duration:

7. Place a selection jumper on the appropriate sleep cycle duration selection pins.
 - Place the jumper on the left two pins, marked 2H, to set the sleep cycle duration to two hours.
 - Place the jumper on the middle two pins, marked 4H, to set the sleep cycle duration to four hours.
 - Place the jumper on the right two pins, marked 6H, to set the sleep cycle duration to six hours.

Note: Selection jumpers are included in the hardware bag.

2.8 Select Pet Immunity

Pet immunity allows the EN1241-60 to ignore the movement of small animals.

8. Place a selection jumper on the appropriate pet immunity selection pins.
 - Place the jumper on the left two pins, marked 55lb/25kg to select pet immunity for animals up to 55 pounds (25 kilograms) in weight.
 - Place the jumper on the right two pins, marked 33lb/15kg to select pet immunity for animals up to 33 pounds (15 kilograms).

Note: If neither option is selected, the EN1241-60 will default to the 55lb/25kg selection.

2.9 Adjust sensitivity

The sensitivity of the activity sensor can be adjusted to fit your specific application. To adjust sensitivity:

9. Use a philip's head screwdriver to turn the sensitivity adjustment dial.
 - Turn the dial to the left, towards the minus sign, to decrease the activity sensor's sensitivity.
 - Turn the dial to the right, towards the plus sign, to increase the activity sensor's sensitivity.

2.10 Register the Transmitter

The EN1241-60 must be registered with the system receiver in order to be monitored and supervised. Each EN1241-60 has a unique factory-programmed identification number.

Note: The transmitter's unique identification number is the eight digit serial number found on the serial number label.

Refer to the receiver installation instructions for details about registering the transmitter.

10. When prompted, press the reset button.

11. Replace the EN1241-60 cover.

12. Replace the housing screw.

Note: For UL 2560 installations, transmitters must have a minimum check-in time of 60 minutes.

Caution: The EN1241-60 should be tested after registration to ensure operation. To test the EN1241-60, activate each of the conditions and ensure an appropriate response.

Note: The EN1241-60 retains programming data in non-volatile memory. It does not require re-programming after loss of power.

2.11 Mount the Transmitter

Mount the transmitter.

13. Remove the EN1241-60 printed circuit board from the housing.

14. Use the included hardware to mount the EN1241-60 housing back plate to the mounting surface.

- If using the wall tamper function for increased security, mount the housing back plate per Figure 3, ensuring the tamper switch is depressed.

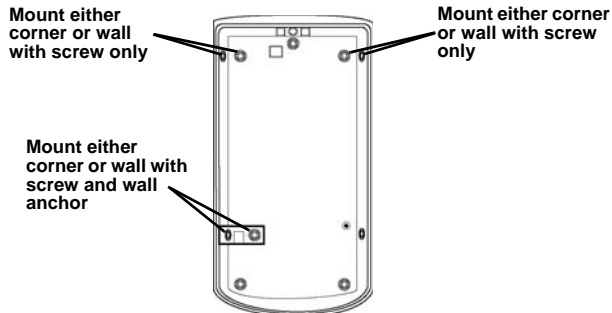

Figure 3 EN1241-60 mounting back plate

- If not using the wall tamper, mount the housing back plate using all appropriate hardware.

3 Mounting Considerations

The following should be considered when mounting the EN1241-60:

- The activity sensor should be mounted such that the expected intrusion motion is perpendicular to the protection zones
- The activity sensor may not detect motion behind obstructions, including blinds, curtains, and drapes
- The activity sensor should be mounted on a solid, vibration-free mounting surface
- The following may cause false alarms:
 - Fans.
 - Blowers.
 - Drafts.
 - Windows.
 - Heat and cooling sources.
 - Sunlight.
 - Animals.

4 Optional Ceiling/Wall Mount Application

The optional ceiling and wall mount brackets are available separately from Inovonics, part number ACC665.

Note: Applications that require the back tamper cannot use the ceiling or wall mount bracket.

Ceiling mount

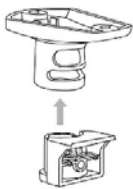

Wall mount

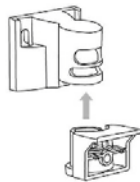

Figure 4 Ceiling and wall mount brackets

To mount a ceiling or wall bracket:

1. Remove the pcb board.

2. Attach the housing to the bracket.

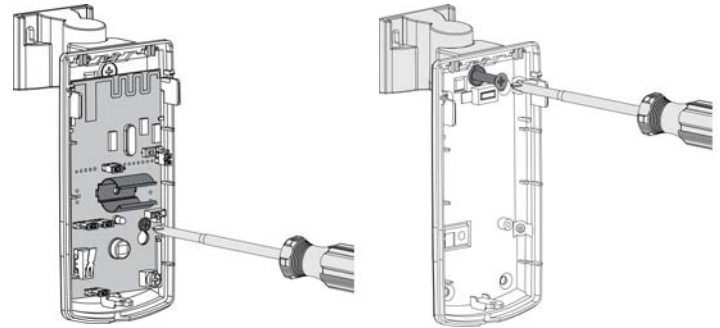

Figure 5 Remove the pcb board and attach the housing to the bracket

3. Replace the pcb board.

5 Test the EN1241-60

Caution: The EN1241-60 should be tested after registration, and at least once a year thereafter, to ensure operation. To test the EN1241-60, activate each of the conditions and ensure an appropriate response.

5.1 Perform a Walk Test

The walk test is performed to ensure motion is sensed and an RF transmission results. To perform a walk test:

1. Swipe a magnet past the reed switch. The five minute walk test will begin; every time motion is sensed, the LED will light.

Note: During walk test, the EN1241-60 will not transmit alarms when motion is detected; only the LED will light.

2. Walk in front of the activity sensor to test the sensor.
3. After five minutes the walk test will automatically end.

6 Operation

The EN1241-60 transmitter signals an alarm condition when motion is detected by the sensor.

6' 10" -
8' 10"

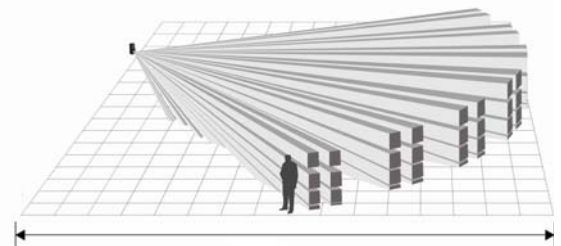

49'

Figure 6 Standard mounting height and range

7 US Patent Numbers

- 7,154,866.
- 7,554,932.
- 7,746,804.
- Other patents pending.

8 Specifications

Dimensions: 4.5"H x 2.5"W x 1.6"D (11.4 cm x 6.4 cm x 4.1 cm).

Detection method: Quad element PIR.

Storage temperature: -4° to 140°F (-20° to 60°C).

Operating temperature: 32° to 122°F (0° to 50°C), 90% relative humidity, non-condensing.

Humidity: 0 - 90% (non-condensing).

Typical battery life: 2 years.

Battery: 3V LiMnO₂, BAT604, Panasonic CR123A or equivalent.

Power requirement: 3VDC, 60 mA.

Temperature compensation: Yes.

Tamper: Housing and wall tamper.

PIR RF interference immunity: Greater than 30 v/m 26 MHz - 1 GHz.

Stabilization period: one minute.

Alarm lockout time: two, four, or six hours.

Walk test period: five minutes.

Mounting height: 6' 10" to 8' 10" (2.1 to 2.7m).

Compatible receiver for UL 2560 installations: EN6080 or EN6040-T.

Compatible repeater for UL 2560 installations: EN5040-20T.

Note: The EN1241-60 is a supplemental device that can be installed in a UL 2560 certified system.

9 Television and Radio Interference

This equipment has been tested and found to comply with the limits for a Class B digital device, pursuant to Part 15 of the FCC Rules. These limits are designed to provide reasonable protection against harmful interference in a residential installation. This equipment generates, uses and can radiate radio frequency energy and, if not installed and used in accordance with the instructions, may cause harmful interference to radio communications. However, there is no guarantee that interference will not occur in a particular installation. If this equipment does cause harmful interference to radio or television reception, which can be determined by turning the equipment off and on, the user is encouraged to try to correct the interference by one or more of the following measures:

- Reorient or relocate the receiving antenna.
- Increase the separation between the equipment and receiver.
- Connect the equipment into an outlet on a circuit different from that to which the receiver is connected.
- Consult the dealer or an experienced radio/TV technician for help.

10 FCC Part 15 and Industry Canada Compliance

This device complies with part 15 of the FCC Rules and Industry Canada license-exempt RSS standard(s). Operation is subject to the following two conditions: (1) this device may not cause interference, and (2) this device must accept any interference, including interference that may cause undesired operation of the device.

Le présent appareil est conforme aux CNR d'Industrie Canada applicables aux appareils radio exempts de licence. L'exploitation est autorisée aux deux conditions suivantes : (1) l'appareil ne doit pas produire de brouillage, et (2) l'utilisateur de l'appareil doit accepter tout brouillage radioélectrique subi, même si le brouillage est susceptible d'en compromettre le fonctionnement.

Caution: Changes or modifications not expressly approved by the party responsible for compliance could void the user's authority to operate the equipment.
