



The Inovonics EN7581 TapWatch gateway lite provides the reliability of submetering hardware with the anytime/anywhere access of the cloud. Using the TapWatch gateway lite for smaller residential or light commercial properties, providers can directly access reads data for integration into billing software via TapWatch APIs, or manually access reads data through the TapWatch application.

Product Features

Combines the receiver and data logger functionality into a single gateway

Supports over-the-air updates

Full compatibility with previously installed EchoStream systems

TapWatch Gateway Specifications

Weight:	1 lb. 3.54 oz
Power requirement:	Line power: The Inovonics ACC610 transformer, or a 12-14V AC intrinsically safe power supply capable of supplying at least 20VA, or a 12-15V DC power supply capable of supplying at least 20VA; POE: IEEE 802.3af-2003 compliant
Router requirements:	The router must assign addresses via DHCP; the DHCP lease of the router must be set to a non-zero and non-infinite value, and should be set to a value greater than 30 seconds; The router must allow outbound connections on the following ports: DNS (53), HTTPS (443), NTP (123)
Connectivity:	10/100/1000BASE-T, DHCP
Transmitters/repeaters supported:	The TapWatch gateway lite can support up to 50 transmitters and/or repeaters
Storage capacity:	Equivalent to messages for up to 1000 transmitters at 60-minute intervals
Operating environment:	
Temperature:	32° - 140°F
Humidity:	Up to 90% (non-condensing)
Market:	North America, Australia, New Zealand
EchoStream® frequency:	902-928 MHz, frequency hopping spread spectrum
Regulatory compliance:	FCC part 15 class B, Industry Canada RSS 247, RCM

Inputs



Dimensions

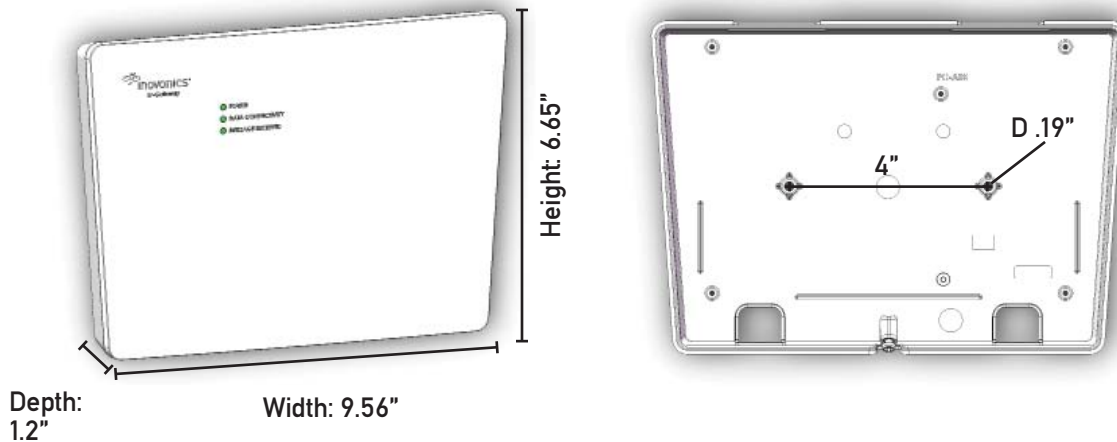

Reference Materials (available at www.inovonics.com)

TapWatch Gateway Installation Instructions

TapWatch Application User Manual

Inovonics Product Catalog: North America

Technical documents

For technical documents visit us at <http://www.inovonics.com/support/tech-documents/> or use the QR code below.

- The range and performance of any wireless product depends on the structure and environment in which it operates.
- Continual enhancements to our products may cause specifications to change without notice.
- Patents: 7,154,866; 7,554,932; 7,746,804; others pending.

