

FA206C Frequency Agile[®] 900 MHz Transmitter 360° Passive InfraRed Motion Detector

Installation and Operation Manual - 04097B

IMPORTANT NOTES

- Products, unless specifically noted, are intended for indoor use.
- Manually test all products regularly.
- These products are designed to be installed and maintained by professional security technicians.

OVERVIEW:

The FA206C is a wireless, ceiling-mounted 4-element passive infrared intrusion detector providing protection from intruders by pyro-sensor array. Micro-controller PIR signal analysis with special ASIC technology for PIR pulse processing increases immunity to RFI, vibration, static, lightning, ambient temperature changes and other common causes of false alarms.

LOCATING THE DETECTOR:

Choose a location most likely to intercept an intruder. Refer to the following recommendations for the best installation location:

- Temperature changes: Do not install the detector outdoors or in a place exposed to sudden temperature changes, or near equipment such as air conditioners, ventilators, fans, heaters, etc.
- Bright light: Avoid bright light, direct or reflected sunlight, automobile headlights or other light sources.
- Moving Objects: Objects that may move or vibrate, such as curtains, window blinds or decorative banners can cause false alarms.
- Exposure to contaminants: Airborne vapors, mists, steam, or fumes can cause detector malfunction.
- Curtains, Glass, Screens: Infrared energy cannot pass through opaque objects or through transparent or semi-transparent materials such as glass, paper, or curtains. Barriers of these materials create "blind-spots" in intrusion protection.
- Detection Zones: Refer to zone pattern diagrams to determine optimal mounting locations.

MOUNTING THE DETECTOR:

1. Remove cover from the detector body by loosening the lock screw about 5mm and turning the cover counterclockwise. (See Figure 3.)
2. Remove the body from the bracket by turning it counterclockwise.
3. Mount the bracket to the ceiling. Hold the bracket on the ceiling. Mark and drill 4 holes for installation.
4. Attach the detector body. Install the battery and place the detector body so that the arrow is aligned with the dot on the bracket. Turn clockwise until the arrow on the body aligns with the arrow on the bracket. (See Figure 3.)
5. Set Pulse Sensitivity jumper in desired position. (See Figure 1.)
6. Program the transmitter as described below.
7. Attach the cover. Place the four tabs of the cover into the matching notches in the base and turn the cover clockwise until it fits tightly.
8. Secure sensor cover lock screw.

MOUNTING HEIGHT

The FA206C can be mounted to a maximum height of approximately 18 feet (5.5 meters). At 18', the PIR detection pattern is about twice the diameter of a 10' (3m) installation. As mounting height increases, distance between detection zones also increases toward the perimeter, and the effects of factors such as floor surface temperature and intruder direction and speed are intensified. This can contribute to reducing speed of detection. (See Figures 4-6.) Every installation should

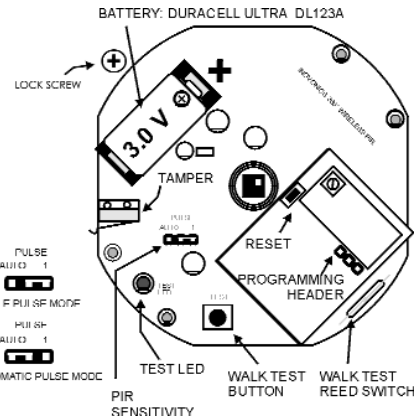
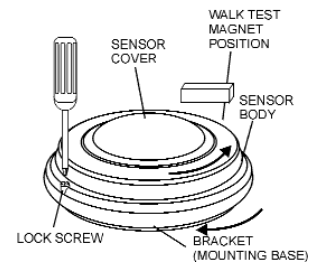

Figure 1

REMOVE COVER AND BRACKET

Figure 2



BRACKET WITH SILICON GASKET

Figure 3

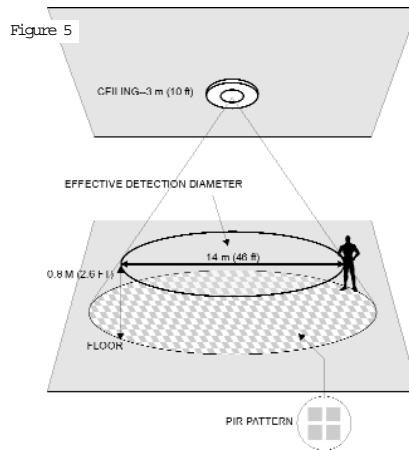
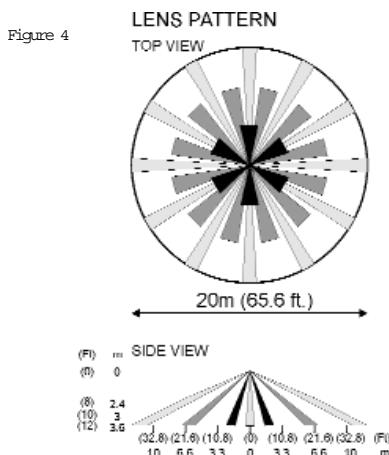
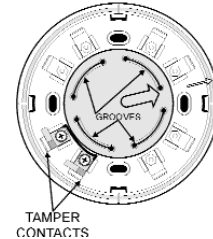

Figure 6

Approximate Effective Detection Diameter*

PIR Height	Diameter
8'(2.4m)	31' (9.3m)
10'(3m)	38' (11.7m)
12'(3.6m)	46' (9.34m)
18'(5.5m)	70' (21m)

* See "Mounting Height"

include a Walk Test of detection zones, including intrusion paths crossing the edges of the zones.

PIR SENSITIVITY

The Pulse Count jumper provides control for normal or difficult operating environments. Automatic Pulse Count is recommended for reliable operation in environments which may be subject to temperature fluctuations that might cause false alarms. The Single Pulse Count mode is more sensitive to minor temperature variations, and should be used in sites where variant heat sources will not cause alarms (See Figure 1.)

PROGRAMMING THE FA206C:

1. Remove the FA206C cover.
2. Enter programming mode for the receiver unit, using recommended options.
3. Connect the programming cable between the transmitter and the receiver.
4. Press the transmitter reset button.
5. When programming is complete, disconnect the programming cable.

Programming Options:

External contacts:	N/C (only)
EOL:	No (only)
Internal Contact:	No (only)
Check-in:	60 seconds (recommended)*

*To extend battery life, actual check-in interval is triple the program value.

Note: The FA206C retains programming data in non-volatile memory. It does not require re-programming after loss of power. Install a new battery and press the reset button to re-initialize the transmitter and restore programming.

WALK TEST:

With the cover on the unit, quickly (less than ½ second) pass a magnet near the Walk Test Reed Switch, located on the opposite side of the lock Screw. This activates a 1-minute walk test mode. Within this period, the Test LED will light every time the PIR senses motion. The unit will not transmit alarm signals during this test period. Walk Test can also be initiated by a quick press and release of the Test Button.

TRANSMISSION TEST:

With the cover on the unit, hold a magnet near the Walk Test Reed Switch, located on the opposite side of the Lock Screw, for at least 1 second. This activates a 1-minute transmission test mode. Within this period, the unit will transmit alarm and restoral cycles at regular intervals for approximately one minute. The LED will light every time the unit transmits. Transmission Test can also be initiated by a one-second press and hold of the Test Button.

Note: The LED indicator lights only during 1-minute walk test period, and during transmission test.

OPERATION:

The FA206C transmitter signals an alarm condition when motion is detected by the sensor. Once an alarm condition is signaled, further alarms are suppressed until no motion is sensed for a period of more than 90 seconds.

TECHNICAL SPECIFICATIONS:

Dimensions:	5.2" x 2.25" (131mm x 57mm)
Weight:	6.52 oz. (185g)
Detection Method:	4-element PIR
Operating Temperature:	32°F to 120°F (0°C to 49°C)
Humidity:	10% to 90% non-condensing
Battery:	Inovonics BAT604 (3.0V lithium Duracell DL123A) Note: Battery is supervised
Typical Battery Life:	2 years in location with low to moderate activity*
Visible Light Protection:	Stable against halogen light 8 feet (2.4m) or reflected light
Temperature compensation:	Yes
Pulse Count:	Selectable single pulse or multiple pulse
LED Indicator:	lights only during 1-minute walk test period and transmission test.

* The battery life of a PIR transmitter is highly dependent on "traffic" in its coverage area. PIRs installed in high-traffic areas may experience reduced battery life.

CHANGING THE BATTERY

1. Carefully remove old battery.
2. Install new battery.
3. IMPORTANT: Press reset button to re-initialize the transmitter.

Discard old battery in accordance to the local laws and practices. Inovonics Wireless does not take responsibility for batteries that are not discarded properly.

WARRANTY & DISCLAIMER

Inovonics Wireless Corporation ("Inovonics") warrants its products ("Product" or "Products") to conform to its own specifications and to be free of defects in materials and workmanship under normal use for a period of twenty-four (24) months from the date of manufacture. Within the warranty period, Inovonics will repair or replace, at its option, all or any part of the warranted Product. Inovonics will not be responsible for dismantling and/or reinstallation charges. To exercise the warranty, the User ("User", "Installer" or "Consumer") must work directly through their authorized distributor who will be given a Return Material Authorization ("RMA") number by Inovonics. Details of shipment will be arranged directly through the authorized distributor.

This warranty is void in cases of improper installation, misuse, failure to follow installation and operating instructions, alteration, accident or tampering, and repair by anyone other than Inovonics.

This warranty is exclusive and expressly in lieu of all other warranties, obligations or liabilities, whether written, oral, express, or implied. There is no warranty by Inovonics that Inovonics product will be merchantable or fit for any particular purpose, nor is there any other warranty, expressed or implied, except as such is expressly set forth herein. In no event shall Inovonics be liable for an incidental, consequential, indirect, special or exemplary damages, including but not limited to loss of profit, revenue or contract, loss of use, cost of down time, or interruption of business, nor any claim made by distributor's customers, or any other person or entity.

This warranty will not be modified or extended. Inovonics does not authorize any person to act on its behalf to modify or extend this warranty. This warranty will apply only to Inovonics Products. All other products, accessories or attachments used in conjunction with Inovonics equipment, including batteries, will be covered solely by their own warranty, if any. Inovonics will not be liable for any direct, incidental or consequential damage or loss whatsoever, caused by the malfunction of Product due to products, accessories, or attachments of other manufacturers, including batteries, used in conjunction with Inovonics Products.

The User recognizes that a properly installed and maintained security system may only reduce the risk of events such as burglary, robbery, personal injury and fire. It does not insure or guarantee that there will be no death, personal damage, and/or damage to property. Inovonics does not claim that the Product may not be compromised and/or circumvented, or that the Product will prevent any death, personal and/or bodily injury, and/or damage to property resulting from burglary, robbery, fire or otherwise, or that the Product will in all cases provide adequate warning or protection.

Inovonics shall have no liability for any death, injury, or damage, however incurred, based on a claim that Inovonics Products failed to function. However, if Inovonics is held liable, directly or indirectly, for any loss or damage arising under this limited warranty or otherwise, regardless of cause or origin, Inovonics' maximum liability will not in any case exceed the purchase price of the Product. This will be the complete and exclusive remedy against Inovonics.

I Warning: The User should follow all installation, operation, and maintenance instructions. The User is strongly advised to conduct Product and systems tests at least once each week. Changes in environmental conditions, electric or electronic disruptions, and tampering may cause the Product to not perform as expected.

I Warning: Inovonics warrants its Product to the User. The User is responsible for exercising all due prudence and taking necessary precautions for the safety and protection of lives and property wherever Inovonics Products are installed. Inovonics strongly advises the User to program Products to be supervised when used in applications affecting life safety. Users are warned that unsupervised devices are subject to undetected failure due to malfunction, battery failure, tampering, or changes in environment.

